

PF Series

Powder Feeder



Constructed of electro-polished stainless steel, the PF Series Powder Feeder from PROCESS CONTROL delivers unparalleled accuracy. (Shown above is a PFC20)

The PF Series Powder Feeder from Process Control offers operators unprecedented metering accuracy from ultra low rates up to 3000 pounds per hour.

Incorporated into the brushed stainless steel design is a unique round-to-trough feeding area which provides more consistent mass flow for better metering accuracy. The feeder is designed with a steep wall, removable hopper which features a dust-tight band clamp for easy mounting of hopper extensions and quick disassembly for clean out. The bottom

trough design is optimized to provide maximum material exposure to the auger.

Separate PWM-DC-type drives for the agitator and metering auger allow appropriate agitation at all auger speeds. Metering augers are available in full pitch or 1/2 pitch configurations with helix diameters from 1/4 inch to 2 -1/4 inches. The PF Series can be configured with controls for intermittent agitator operation, which is particularly useful when operating at very low rates. Additionally, this variable speed agi-

tator permits thorough mixing in all areas of the metering section.

The unprecedented metering accuracy of the PF Series Powder Feeder is enhanced by a proprietary filtering method (pat. pend.) which allows very accurate and consistent gravimetric metering in the presence of ambient vibration and electrical noise.

The feeder is available either as a stand alone or configured as an element on a gravimetric blender. ■

Standard features

- All mechanical components are disassembled from the drive end, without the uses of tools.
- Communication protocols supported include: EtherNet/IP, Allen Bradley [dh+], CCM, Siemens 3694, Profibus, DeviceNet, ControlNet, SPI, Modbus TCP and Modbus/Extended, as well as proprietary EPCC and ASCII.

Options

- The electronics, including the weigh system, drive system, and operator interface, can be factory prewired.
- PCCWeb® Software for remote monitoring, control, and trouble shooting.
- Trend Manager for tracking and recording production history.
- Material Manager for tracking and recording elapsed material usage.

PF Series Powder Feeder

[] dimensions are in mm

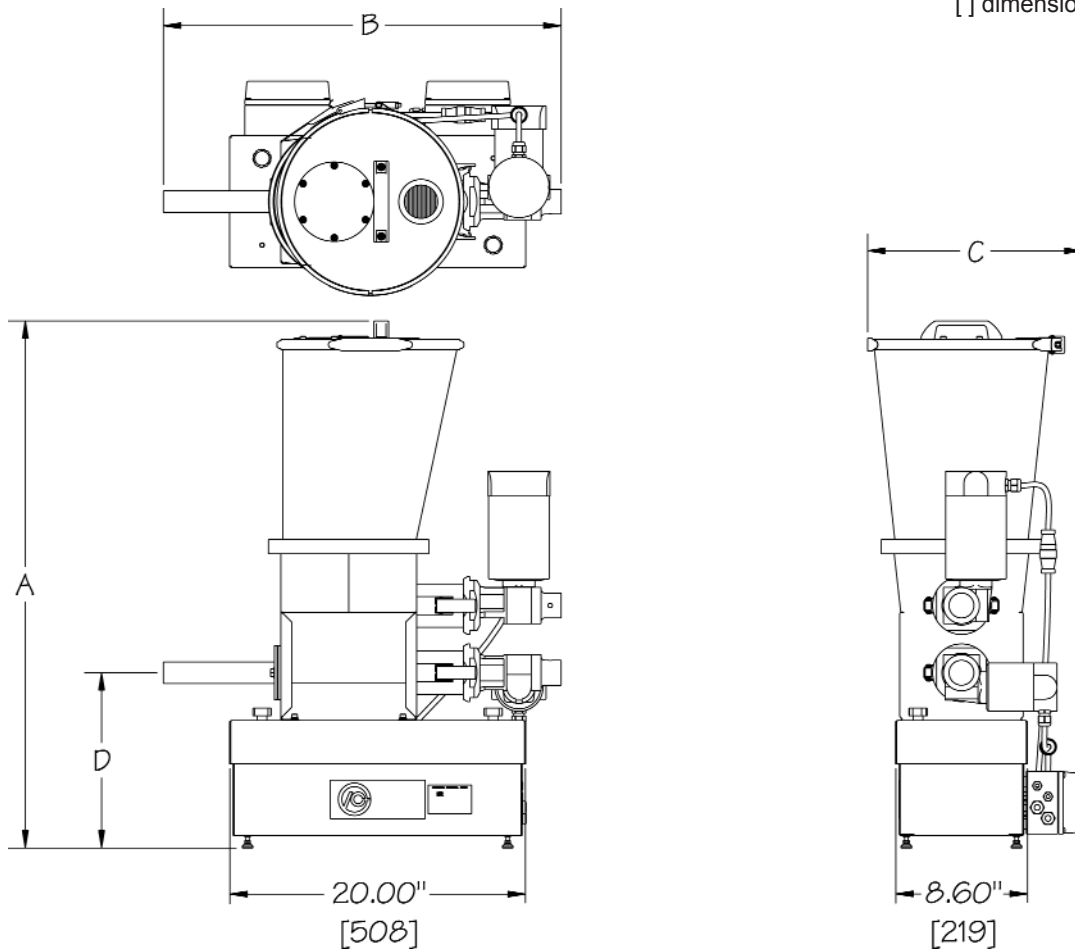

SPECIFICATIONS for PF SERIES POWDER FEEDER

Model Number	Auger Size	Nominal Rate PPH [kgph]	Dimensions - Inches [mm]				Ship Weight lbs. [kg]
			A	B	C	D	
PFB03	.31 [8]	0-240 [0-528]	30.30	27.00 [686]	15.25 [387]	12.12 [308]	106
PFB07	.5 [13]		[770]				[233]
	.75 [19]	35.20	[894]		110		
	1.0 [25]					[242]	
PFC20	1.0 [25]	24-3000 [53-6600]	50.00	17.66 [448]	12.30 [312]	118	
	1.5 [38]		[1270]			[260]	
	1.75 [44]						
	2.25 [57]						



PROCESS CONTROL Corporation
World Headquarters
 6875 Mimms Drive, Atlanta, GA 30340 USA
 Tel: (770) 449-8810 Fax: (770) 449-5445
 www.process-control.com

PROCESS CONTROL GmbH
 Industriestrasse 15, 63633 Birstein, Deutschland
 Tel: (+49) 0 60 54-91 29 0 Fax: (+49) 0 60 54-91 29 99
 E-Mail: ProcessControl@t-online.de