

## **Cleaning Yes - Washing No** **The Dry Cleaners Type MR**

### **The Problem**

For the production of high quality pellets made from waste plastic waste a thorough cleaning is essential. Labels and all sorts of adhering dirt, e.g. residues from food, have to be totally removed. Today the required washing technology is well developed and the related processes are well proven. The basic disadvantage of the plastic washing is the expensive physical and chemical waste water treatment.

Beside this sewage sludge consisting of paper fibers and dirt consists of 50 to 70% of water which boosts the disposal costs. Moreover, the costs for fresh and sewage water increase continuously over the years.

### **The Solution**

Pla.to has developed a new system for a mechanical pretreatment of waste plastics. Fast rotating blades in the centrifuge subject plastics to significant mechanical stress and deformation.



*Dry Cleaner MR110*



Thus, paper and cardboard are de-fibered to the smallest elements of the paper structure- the cellulose fibre. Additionally, adhering dirt is spun off the plastic and can be sucked off pneumatically. The machines are designed for 24-hour and 365-day operation.

### **The Advantages at a Glance**

Dry mechanical cleaning of the plastic waste significantly reduces the effort required for the downstream wet washing. The undesired paper, dirt and organic residues are separated from the plastics. Therefore the waste stream is dry and the amount of waste generated by wet washing technology is minimised by up to 50%. In addition, the costs for waste disposal are significantly reduced.



*Paper fibers and dirt separated with the Dry Cleaner*

The cleaning efficiency is between 80 and 98% depending on the type and grade of contamination. Beside paper fibers and dirt even part of the label glue is separated with the dry cleaner.



The dry cleaner is equipped with a scraper which cleans continuously the screen basket and the housing of the device. The scraper forces fibers and dirt into an auger which discharges the reject out of the machine. By this jams can be avoided.

For lubrication purposes the machine is equipped with a central lubrication dispenser. This facilitates maintenance of the central bearing.

The only wearing parts which have to be replaced are inexpensive hardened steel plates. The replacement period depends on the type and grade of contamination and is usually between 2 and 3 months.

### Performance

The cleaning result depends on the type and grade of contamination. Newspapers and many other types of paper can be easily removed. More difficult to remove are tough beverage cartons. The humidity coming with the input has an influence on the cleaning results. Best way to prove the amazing new cleaning technology is a test with our material at our customer's trial plant which is free of charge. The paper separators are built in various sizes.

	MR37-50	MR75-70	MR90-90	MR110-125
rated power [kW]	37	45-75	75-90	90-110
throughput post-consumer mixed plastics [kg/h]	150-200	200-300	600-900	1000-1200
throughput PE/PP film thickness > 20 µm [kg/h]	100-150	150-300	500-700	800-1000
throughput PET-or HDPE-flakes [kg/h]	500-600	700-1000	2000-2500	3000-4000

### Design of a Dry Mechanical Cleaning plant

A complete dry cleaning system usually exists of the following components:

#### Feeding Auger

The feeding auger releases lumps of film and insures an homogenous mass flow to the air separator downstream.

#### Air Separator

In case of foreign objects in the input Plato recommends to install an air separator upstream the centrifuge to remove e.g. rocks, pebbles, lumps of clay, wood and others which are undesired or might harm the centrifuge.

### Dry Cleaner

Core component of the cleaning system is the dry cleaner. Clean plastic and reject leave in separate stream the machine.

### Pneumatic System

For a high cleaning efficiency and a trouble free operation it is essential to design a proper pneumatic system. This includes fans, cyclones and rotary lock separator. Plato offers tailor made pneumatic system which insure a minimum of wear and dust emissions.

### Dust filter

The conveying air is dusty and should be cleaned with the help of a closed dust filter.

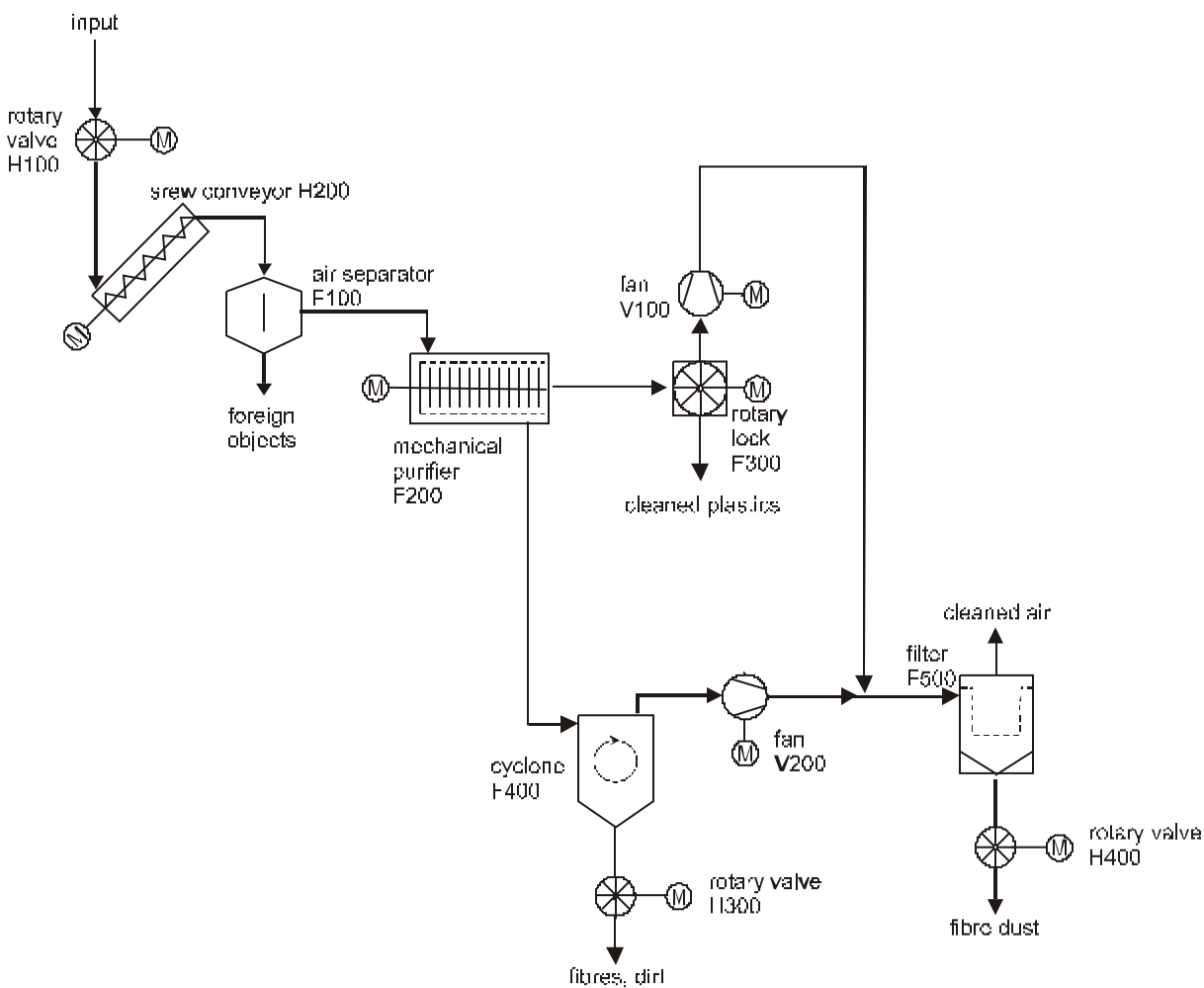

*Process diagram of dry mechanical purification system*

### Customer Demonstration Plant

We offer the opportunity to make test runs with customer material at our demonstration site close to Cologne. The suitable input size for film is 40-60mm and for PET and HDPE flakes 10 to 20 mm. An amount of roughly 100 kg is enough to get a good impression of the capabilities of our technology.



*Pla.to operates a demonstration plant to run trials with customer material*



*Example of dry mechanical cleaning performance: PET-Flakes before and after*



*MR37 in stainless steel*

Represented in the USA by:

**Extrusion  
Auxiliary Services**

*Your Extrusion Process & Equipment Experts*

3337 Forest Vista Drive  
Dacula, GA 30019

Phone: 678-714-5218  
Fax: 678-714-5264

Email: [Info@extrusionauxiliary.com](mailto:Info@extrusionauxiliary.com)