



## METROLINK

### Material selection system

The fully automatic material selection and distribution system.

METROLINK assures that in your production process every desired connection of a material to a processing machine can be made quickly and reliably; no contamination guaranteed. Fixed pipe connections throughout the whole production process until the next material change ensures maximum security.

The standard version supplies up to 15 processing machines automatically with up to 16 material options.

METROLINK stands out for user friendly operation, it can run fully automatically with a METROnet PLC microprocessor control or simply manually.

The ideal building block for your materials handling system – METROLINK.



# METROLINK

## Your benefits:

- Space saving – due to compact vertical design
- Wear resistant – through eliminating the need for flexible hoses
- Long life – due to rigid pipe construction
- Safe – due to secure pipe connections throughout the whole conveying cycle
- Low maintenance – because of the small number of switching operations
- Contamination free – due to automatic purging before every conveying cycle
- Quality assured – since material selection will always be correct
- Optimised capacity – there are no switching operations during normal conveying
- User friendly – easy to operate
- Easily expandable – due to modular construction

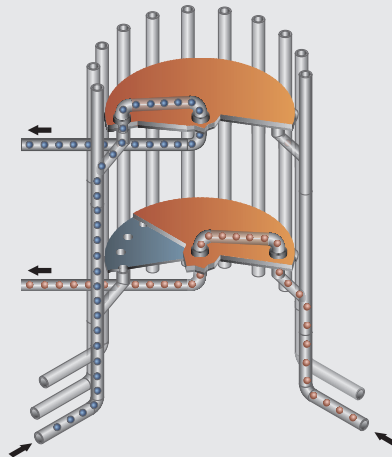
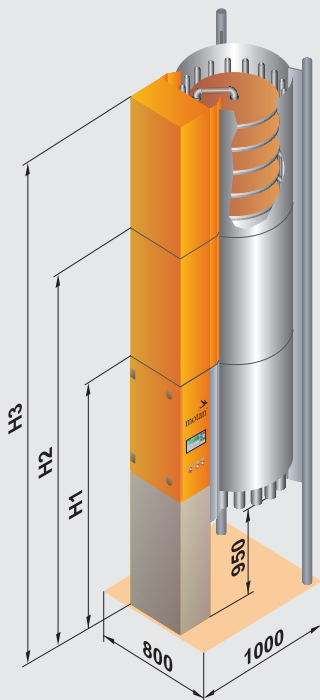

### Technical data

	METROLINK 45	METROLINK 60
Number of material lines	4 - 16	4 - 12
Number of machines	3 - 15	3 - 15
Ø Material lines (mm)	45	60
Power supply 1/N/PE (V/Hz)	230/50	230/50
Air pressure (bar)	4 - 10	4 - 10
Dimensions (mm)		
H1	3 - 5 material outlets	2000
H2	6 - 10 material outlets	2960
H3	11 - 15 material outlets	3920

Subject to technical changes.

Motan Pte. Ltd.  
China/Beijing  
Tel +86 10 6525-8815/16/17  
Fax +86 10 6522-2522  
motanbj@motan.com.cn

Motan Pte. Ltd.  
China/Shanghai  
Tel +86 21 6351-2999  
Fax +86 21 6351-3555  
motan.sh@motan.com.cn

Motan SAS  
France  
Tel +33 1 608690-18  
Fax +33 1 608690-29  
info@motan.fr

Motan GmbH/North  
Germany  
Tel +49 5223 68544-0  
Fax +49 5223 68544-11  
motan.ger.n@motan.de

Motan GmbH/South  
Germany  
Tel +49 7562 76-0  
Fax +49 7562 76-111  
motan.ger.s@motan.de

Motan Ltd.  
Great Britain  
Tel +44 1235 5500-11  
Fax +44 1235 5500-33  
sales@motan.co.uk

Motan India Liaison Office  
India  
Tel +91 44 2445-3779  
Fax +91 44 2440-4196  
motan.india@motan.com

Motan S.r.l.  
Italy  
Tel +39 02 9272121  
Fax +39 02 92148392  
motan.it@motan.com

Motan Pte. Ltd.  
Singapore  
Tel +65 6873-7666  
Fax +65 6873-7555  
motansin@motan.com.sg

Motan AG  
Switzerland  
Tel +41 41 74861-11  
Fax +41 41 74861-10  
info@motan.ch

Motan Pte. Ltd.  
Thailand  
Tel +66 2 717-1088  
Fax +66 2 717-1080  
motanth@motan.co.th

Motan Inc.  
USA/Plainwell  
Tel +1 269 685-1050  
Fax +1 269 685-1059  
motanusa@motan-inc.com

SEMMIL\*  
Brazil  
Tel +55 11 5522-2200  
Fax +55 11 5687-5012  
vendas@semml.com.br

Larsen & Toubro Limited\*  
India  
Tel +91 44 2249-1932  
Fax +91 44 2249-2471  
krishramani@ltmindia.com

Sangyokiden Co. Ltd.\*  
Japan  
Tel +81 82 928-6150  
Fax +81 82 928-9954  
info@sangyokiden.co.jp

over 90 agencies worldwide \* partners

