

Automatic Edge Trim Recycling System

KAG



KAG - the innovative EREMA solution ...

... for fully automatic edge trim recycling.



Benefits

- Fully automatic control made available
- Self-adjusting operating range when reprocessing edge trim - no manual adjustments necessary
- Low-key service and maintenance
- Minimal thermal damage to the reprocessed material
- Extremely low specific energy consumption
- Very low noise emission (low sound level)



The system is fed

either directly via pipes and edge trim cyclone ① with endless edge trim but optionally also via conveyor belt ② (loose waste, KAG 600 only) or via reel feeder ③ (film from rolls).

Combinations of all feeding methods can be used within limits, increasing the flexibility of the system.

If required, the system can be equipped with a fully automatic control system to adjust the plant throughput to varying amounts of incoming edge trim which must be reprocessed immediately and fed back into the extrusion line.

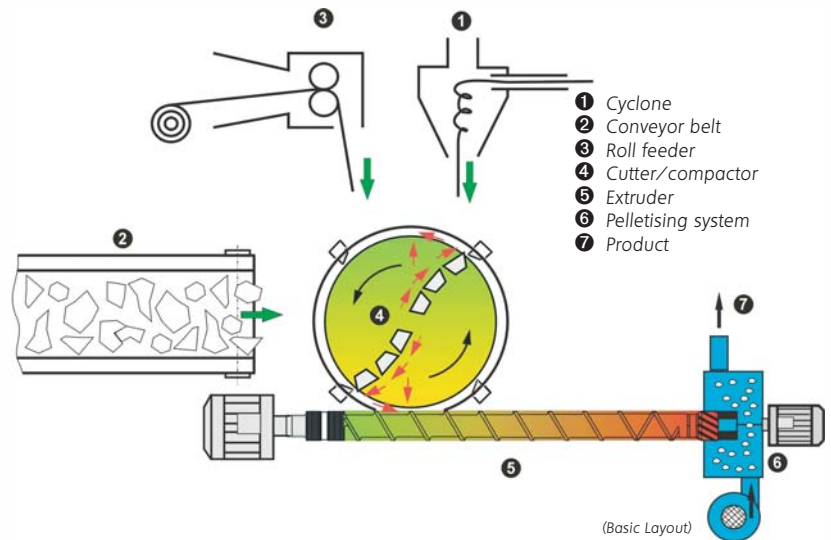

Pelletiser with air cooling

The material is processed

in the cutter/compactor ④. Here the material is cut, dynamically homogenised, heated and predensified at the same time, all in one working step. The fast rotating cutting knives, which can be replaced in a few minutes without readjusting fill the extremely short (approx. 7 D) single-screw extruder efficiently and continuously ⑤ which is directly connected to the cutter/compactor.

In this special, patented extruder the processed material is only partially melted and pelletised in this form ⑥.

This makes reprocessing on the one hand extremely cost efficient and supplies almost no heat degradation, on the other hand it allows, in most cases, the use of air cooled hot die face pelletising systems.

The product

⑦ the system produces is a granulate with high, uniform bulk density and excellent flow characteristics, ideal for further direct processing to make end products.

The system is not suitable for processing low viscosity "sticky" polymer melts such as PP, PET, PA and mixtures of those materials.

Technical data

Type	Cutter/compactor drive guidelines [kW]	Extruder drive guidelines [kW]	Screw diameter [mm]	Effective screw length length-to-diameter ratio (L/D)	Output* PE/PVC kg/h (approx.)
KAG 500**	7,5	4	40	7	10 - 30
KAG 600	11 (18,5)	7,5 (11)	50	7	20 - 60 / 50 - 90

* Output rates are for thin films (when processing thick-walled materials, higher throughputs are possible).

** This system works optionally with a "dynamic die" as pelletising head (without classic die face), produces pellet-like appearance agglomerate with uniform shape and low fines content and enables fully automatic adjustment of incoming edge trim (fully automatic throughput adjustment and start-stop-operation).

Main dimensions:

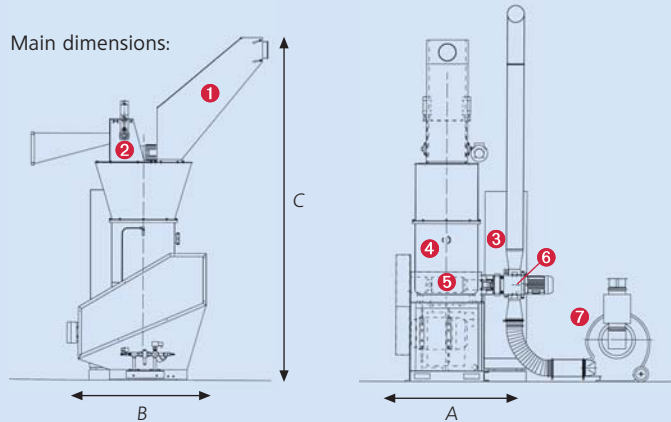

- 1 Cyclone
- 2 Roll feeder
- 3 Control cabinet
- 4 Cutter/compactor
- 5 Extruder
- 6 Pelletising system
- 7 Cooling and conveyor blower

Type	A	B	C
KAG 500	1050	1000	2880
KAG 600	1245	1330	3300

Why Erema?

- High-tech from the world market leader
- Top-notch state-of-the-art recycling technology
- Superior end product quality (pellet)
- Best customer service and care and therefore safety for the user
- Superb reliability, flexibility and productivity
- Your best partner

EREMA - Engineering Recycling
Maschinen und Anlagen Ges.m.b.H.
Freindorf, Unterfeldstraße 3, P.O.B. 38
A-4052 Ansfelden/Linz, Austria
Phone +43/732/3190 - 0
Fax +43/732/3190 - 23
erema@erema.at
www.erema.at

EREMA
NORTH AMERICA INC.
23 Old Right Road - Unit# 2
Ipswich, MA 01938 / USA
Phone +1/978/356-3771
Fax +1/978/356-9003
erema@erema.net
www.erema.net

EREMA JAPAN CORP.
R.No. 202, 1-12-1, Hiranuma,
Nishi-Ku, Yokohama, 220-0023
JAPAN
Phone +81/45-317-2801
Fax: +81/45-317-2803
erema@erema-japan.com
www.erema.at

EREMA Shanghai Office
Room 1304, Tomson Financial Building,
710 Dong Fang Road, Pudong
Shanghai China (200122)
Phone +86/21/6876 6201, 6876 6204
Fax +86/21/6876 6203
erema@erema.com.cn
www.erema.at