

WEIMA High-Powered Shredders

ECO Series



Wood, paper, and plastic materials after shredding.

Performance profile

The compact design of the ECO Series single-shaft shredders makes these units ideal in almost any small- to medium-sized application. The large hoppers are designed for easy loading of scrap wood, plastic rejects, or loose paper.

The ECO shredders are sized to fit next to your production equipment to reduce material handling and increase productivity.

An overview of the ECO Series Shredder

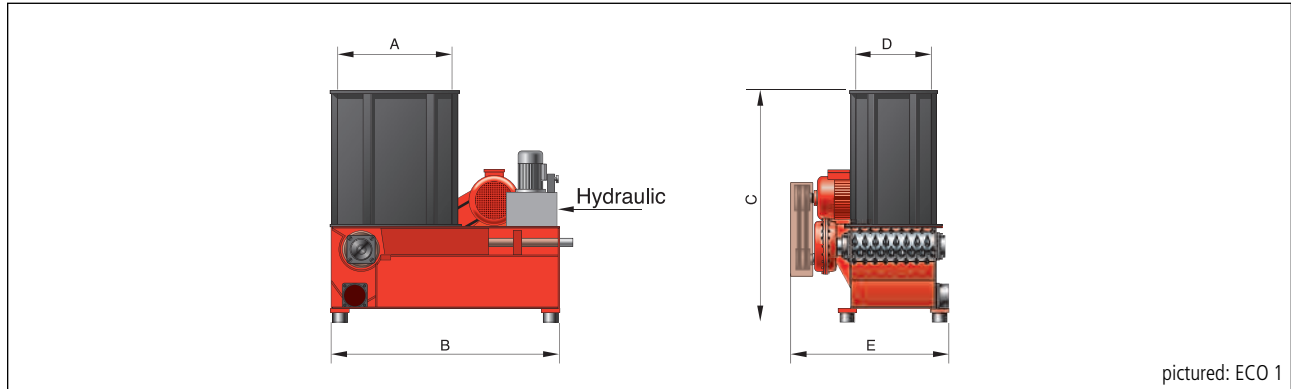

pictured: ECO 1

TECHNICAL DATA

| | ECO 1 | ECO 1.5 | ECO 2 |
|---|---|---------------------------|-----------------------------|
| Feed opening (inch/mm): | 23.6x31.5 / 600 x 800 | 31.5 x 39.4 / 800 x 1,000 | 39.4 x 39.4 / 1,000 x 1,000 |
| Hopper volume (yd ³ /m ³): | 0.8 / 0.6 | 1.2 / 0.9 | 1.75 / 1.3 |
| Throughput: | The throughput rate depends on material and screen size from 3/8"-2" (10-50 mm) | | |
| Rotor diameter (inch/mm): | 10 / 252 | 10 / 252 | 10 / 252 |
| Rotor length (inch/mm): | 23.6 / 600 | 31.5 / 800 | 39.4 / 1,000 |
| Rotor speed (rpm): | 60 - 100 | 60 - 100 | 60 - 100 |
| Power (hp/kW): | 25 / 18.5 | 30 / 22 | 30 / 22 |
| Rotor knives: | 14 | 21 | 27 |
| Screen size (inch/mm): | 3/8 - 2 / 10 - 50 | 3/8 - 2 / 10 - 50 | 3/8 - 2 / 10 - 50 |
| Connection-Ø (inch/mm): | 6 / 160 | 8 / 200 | 8 / 200 |
| Air speed (cfm/m/sec): | 1,300 / 23 | 1,900 / 28 | 1,900 / 28 |
| Weight (approx. lbs/ca.kg): | 2,800 / 1,275 | 3,300 / 1,500 | 3,500 / 1,600 |
| A (inch/mm): | 31.5 / 800 | 39.4 / 1,000 | 39.4 / 1,000 |
| B (inch/mm): | 62.9 / 1,600 | 78.7 / 2,000 | 78.7 / 2,000 |
| C (inch/mm): | 64.5 / 1,640 | 64.5 / 1,640 | 64.5 / 1,640 |
| D (inch/mm): | 23.6 / 600 | 31.5 / 800 | 39.4 / 1,000 |
| E (inch/mm): | 45.3 / 1,150 | 58.7 / 1,490 | 61.4 / 1,560 |

TECHNOLOGY

- V-Rotor cutting system
- 4 x indexable concave cutters
- Fast hydraulic ram
- Low RPM shredder
- Integrated control panel
- High quality sealed bearings
- Variable screen sizes
- Options such as custom hopper & auger



WEIMA America, Inc.

3678 Centre Circle
Fort Mill, SC 29715

803.802.7170 T
803.802.7098 F

info@weimaamerica.com
www.weimaamerica.com